

# Customize torque sensor

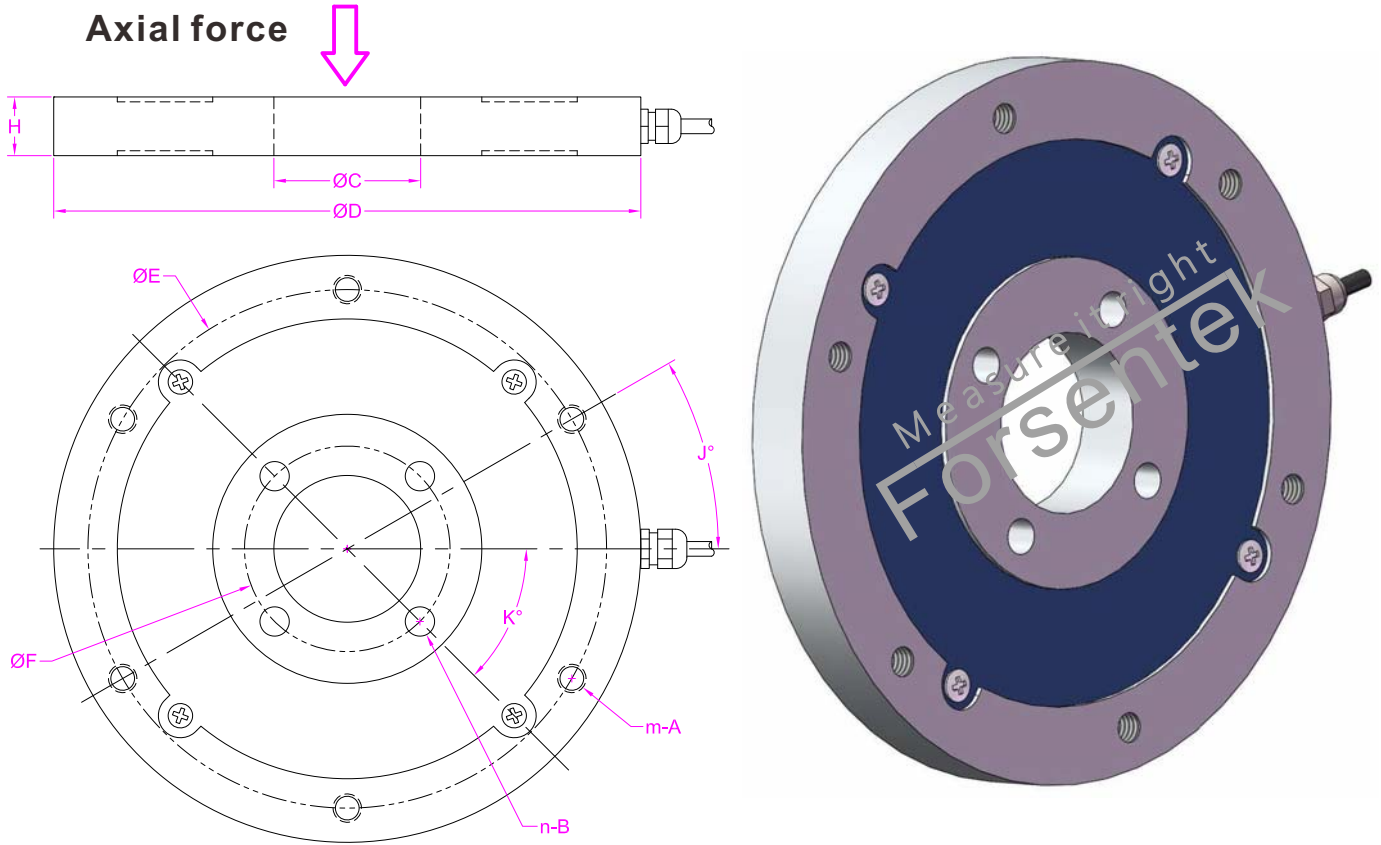

## --- Main parameters ---

Torque range(NM)		Axial force(N)	
Qty of samples		Potential annual Qty	
A		m	
B		n	
C		D	
E		F	
H		J	
K		/	/
Other requirements			

- Dimensions in "milimeter".
- The Axial force may influence the design.
- A and B can be thru hole or threaded hole.
- m and n refers to the number of A and B.
- Please fill in the blank columns with a specific value or acceptable range.
- Customize upon given drawings is also available.